



International Journal of Multidisciplinary and Scientific Emerging Research (IJMSERH)

Volume 13, Issue 3, July-September 2025

Impact Factor: 9.274



Smart IoT-Based Water Quality Monitoring: Real-Time Assessment and Predictive Analytics with Advanced Sensors

Pratik Tawde, Samra Shaikh

Lecturer, Department of Electronics and Computer Engineering, Vidyalkar Polytechnic, Wadala, Mumbai, India

Assistant Professor, Department of Information Technology, M.H. Saboo Siddik Polytechnic, Mumbai, India

ABSTRACT: Water quality monitoring is crucial for maintaining safe and clean water sources for both human use and environmental health. This study introduces an innovative water quality monitoring system that combines state-of-the-art sensor technology, wireless communication, and advanced data analytics to provide real-time assessments of water quality. The system employs strategically placed sensor nodes to continuously measure critical parameters, including pH, turbidity, temperature, and conductivity. By utilizing various technologies, the system effectively analyzes the collected data to detect trends, identify anomalies, and predict potential pollution events. This approach supports early detection of water quality issues, enabling timely and informed interventions to protect aquatic ecosystems and human health. The design integrates Microcontroller-based sensors, a variety of environmental sensors, and advanced analytical techniques for a comprehensive water quality management solution.

KEYWORDS: Esp32, pH Sensor, Temperature Sensor, Water Quality Monitoring, Real-Time Data Analysis

I. INTRODUCTION

A novel approach to maintaining the sustainability and quality of crucial aquatic ecosystems. It presents a sophisticated Water Quality Monitoring system designed to transform our methods for evaluating and protecting water bodies. The primary objective is to develop an all-encompassing platform that integrates state-of-the-art sensor technologies and a smart alert system to tackle the challenges of water quality assessment and purification. The proposed system features advanced sensors that gather real-time water quality data, which is securely stored in a Firebase database. A comprehensive cloud-based interface enables users to visualize, analyze, and interpret both current and historical water quality metrics [1].

Aquaculture is crucial for fulfilling the growing global demand for seafood, but maintaining optimal water quality in aquaculture systems is essential for the health and productivity of aquatic species. This project focuses on the development of a comprehensive monitoring system designed specifically for aquaculture ponds to meet this critical need. The system employs advanced sensors, wireless communication technologies, and sophisticated data analytics to deliver real-time oversight and management of key water quality parameters such as dissolved oxygen, pH levels, temperature, ammonia concentration, and turbidity [2]. It features an automated mechanism that controls the motor based on detected abnormalities in these parameters and sends alerts to users for timely intervention. Moreover, the system includes predictive analytics to forecast potential water quality issues and implement automated corrective measures. This innovative approach supports sustainable aquaculture practices, enhances yield, and minimizes environmental impacts [3].

The development of the Aqua Sense prototype, a sophisticated mechatronic system designed for on-site water quality monitoring. The robot features a specialized water sampling mechanism capable of collecting samples from different depths, enabling comprehensive water quality assessment. Additionally, we detail the system's design for intelligent water quality index classification and introduce a digital twin architecture that serves as a virtual model of the Aqua Sense Prototype for enhanced simulation and analysis [4].

The surge in industrial activities and the neglect of environmental protection regulations have led to increased water pollution, posing significant risks to public health. Ensuring reliable access to clean drinking water is crucial for disease prevention and overall well-being. This article introduces a novel system that leverages the Internet of Things (IoT) for the automated monitoring and management of urban water resources. By integrating advanced embedded technologies,

the system facilitates continuous, real-time surveillance of water quality. An Android-compatible application has been developed to alert users of any water quality issues, enabling remote management. [5].

This in-depth review examines recent advancements in IoT technologies for water and waste water management, focusing on the transformative impact of these innovations. Utilizing a blend of sociometric analysis and systematic review (SR) methodologies, the study investigates trends and co-occurrence patterns within scientific literature related to these technologies. Since 2017, the research has averaged about 15 publications annually, with a peak of 24 articles in 2021[6].

The review highlights the prevalent use of various sensors for water monitoring applications, including those for measuring water levels, flow rates, and pH levels. It also discusses the significant role of wireless communication technologies like Sigfox and Zigbee in enhancing real-time monitoring capabilities [7].

Monitoring and predicting water quality are vital for the sustainable management of water resources and effective environmental protection. Industrial growth and rapid economic development have significantly deteriorated freshwater resources, making it crucial to assess water quality using comprehensive methods. The Water Quality Index (WQI), which analyses physicochemical and bacteriological data, is a useful instrument for assessing the state of surface and ground water [8].

The primary objective of this system is to offer a dependable and efficient solution for the ongoing surveillance of drinking water quality, addressing increasing health concerns related to water safety. The proposed technology leverages real-time monitoring capabilities to ensure water quality standards are met. The collected sensor data is transmitted to a cloud-based server for secure storage and comprehensive analysis [9].

Advanced cloud computing and data analytics techniques are employed to examine this data, detect anomalies, and uncover trends. Predictive models are developed from historical data to foresee water quality changes and assess potential risks. A user-friendly web interface hosted on the cloud enables water authorities, policymakers, and the public to access real-time water quality information, review historical data, and receive alerts about any deviations from standard water quality parameters. This system aims to enhance water management practices and support public health initiatives [10].

Water is essential for sustaining all forms of life, supporting plant growth, aquatic ecosystems, and overall biodiversity. This study presents a novel methodology for water quality assessment through the integration of IoT technology and advanced sensing mechanisms. The raft is equipped with sophisticated sensors to measure critical parameters including turbidity, pH, and temperature, providing a detailed overview of water conditions [11].

A GPS module on the raft facilitates real-time tracking and logs the sampling locations for precise data collection. Data is processed by a ESP32 to ensure its accuracy before being displayed on the Things board platform [12].

II. RELATEDWORK

Assessing water quality is crucial for understanding environmental health and its impact on ecosystems and human communities. The results demonstrate that SVM and XGBoost models achieved training accuracies of approximately 78% and 75%, respectively. Utilizing K-fold cross-validation and techniques to manage convergence issues, the study provides robust, actionable insights for employing in environmental water quality assessments[13].

The advancement of artificial intelligence technologies has led to a growing interest in applying artificial neural networks for water quality assessment. However, raw water quality monitoring data, which consists solely of numerical values without categorical attributes, cannot be directly used as inputs for neural networks. Therefore, this paper addresses this challenge by constructing a comprehensive water quality dataset and employing several methods—single-factor index, principal component analysis, and fuzzy comprehensive evaluation—to categorize the water quality data [14].

Water pollution is a pressing global challenge that affects ecosystems and environmental health on a large scale. Traditional methods of water quality assessment, which rely on manual sampling and laboratory analysis, are often labour-intensive and prone to errors, making them inadequate for timely detection of water quality fluctuations. This

study introduces a cost-effective, portable prototype for real-time water quality monitoring that leverages sensor technology for enhanced efficiency [15]. The system integrates a microcontroller with sensors for measuring temperature, turbidity, pH, and distance, along with an application for visualizing the collected data. Through rigorous testing, the prototype has proven to be reliable and user-friendly, allowing for its deployment in close proximity to water sources to mitigate environmental and biological risks [16].

The impacts of global warming are increasingly evident worldwide, including in Latin America where expanding drought conditions are exacerbating the demand for underground water resources. Despite this growing need, there is a significant gap in both temporal and spatial information regarding the availability and quality of these underground water sources, which hampers effective decision-making [17]. To address this challenge, we propose a novel Internet of Things (IoT)-based water quality monitoring system with embedded edge-processing capabilities. This system is specifically designed for the monitoring of irrigation and drinking water from wells in central Chile, taking into account the region's topographical challenges that affect both power supply and communication infrastructure [18].

Ensuring water quality and preventing pollution is crucial for the sustainability of life and environmental health. Both natural processes and human activities can lead to the deterioration of water quality, but the accelerating pace of urbanization and industrialization is significantly exacerbating these issues [19]. This paper presents a novel solution in the form of a compact, cost-effective unmanned surface vehicle designed to measure key near-surface water quality parameters, including pH, temperature, and turbidity. Utilizing a microcontroller for data processing, the system transmits real-time measurements to a sms interface via a wireless Bluetooth module [20].

Water contamination is a major global health issue, contributing to around 40% of deaths worldwide, highlighting the urgent need for effective real-time water quality monitoring solutions. Recent advancements in wireless communication and sensor technology have paved the way for innovative approaches in environmental monitoring [21]. Leveraging the IoT, which enables the seamless connection and data exchange between devices across diverse settings, this work presents a real-time water quality monitoring (WQM) system utilizing ThingSpeak for efficient and cost-effective management [22].

In recent years, the issue of water contamination has worsened, posing a significant health risk. The quality of lakes and streams, which are primary sources of drinking water, is critical for safe consumption by humans and animals. An Arduino model serves as the core controller to process the data collected by these sensors. This research illustrates the implementation of IoT technology on the ThingSpeak cloud platform for real-time monitoring and analysis of water quality metrics [23].

In many regions, water supply is managed by state governments through various means, with pipelines being the most common method over the decades. Typically, water billing is based on consumption using specific calculation methods. However, issues such as contamination from sewage leaks into pipelines and the presence of harmful substances in supplied water are prevalent. Traditional water quality analysis via sampling is expensive, labor-intensive, and not feasible for daily monitoring [24].

Our system offers a solution by providing real-time monitoring of water quality and quantity. This system eliminates the need for manual reading and updating of water consumption data. In case of contamination, this system immediately alerts the relevant authorities and automatically halts the flow of water using a valve. The contaminated water is then purified, ensuring it is safe for use. It can be installed in various settings, including apartments, individual homes, and industries, adapting to specific requirements. Additionally, it raises awareness among consumers about their water usage and the associated costs [25].

III. PROPOSED SOLUTION

Our solution leverages the Internet of Things (IoT) to monitor water quality in real-time by deploying sensors and networked devices in various water sources such as rivers, lakes, and reservoirs. This system is designed to measure parameters like pH, temperature, dissolved oxygen, turbidity, and conductivity, transmitting data wirelessly to a central database for continuous analysis. By continuously monitoring these parameters, water quality can be assessed in real-time, and appropriate actions can be taken in case of any deviations from the expected values.

The core components of our system include an MCU microcontroller, which acts as the central processing unit for

collecting and managing sensor data. The conductivity sensor determines the water's salinity by measuring its electrical conductivity. A Wi-Fi module facilitates wireless data transmission to the central database, which is accessible through a cloud web page for data storage, analysis, and visualization. The ESP32 serves as a mini-computer for processing data and managing the network, and a Python virtual environment ensures that the project's dependencies are managed, allowing the software to run smoothly across different systems.

To ensure the accuracy and reliability of the monitoring system, regular maintenance and calibration are essential. Tools and procedures for maintenance and calibration are included as part of the system components. Additionally, comprehensive documentation and training materials are provided to facilitate installation, operation, and troubleshooting.

TABLE I. PROOF OF TABLES

Parameter	Sensor Type	Measurement Range	Accuracy	Frequency of data collection
pH	pH Sensor	0-14	±0.01 pH	Every 5 minutes
Temperature	Temperature Sensor	-10°C to 85°C	±0.5°C	Every 5 minutes
Dissolved oxygen	DO Sensor	0-20 mg/L	±0.1 mg/L	Every 5 minutes
Turbidity	Turbidity Sensor	0-1000 NTU	±1 NTU	Every 5 minutes
Conductivity	Conductivity Sensor	0-200 mS/cm	±1%	Every 5 minutes

This comprehensive system ensures real-time monitoring and proactive management of water quality, addressing a critical need for safe drinking water and environmental protection.

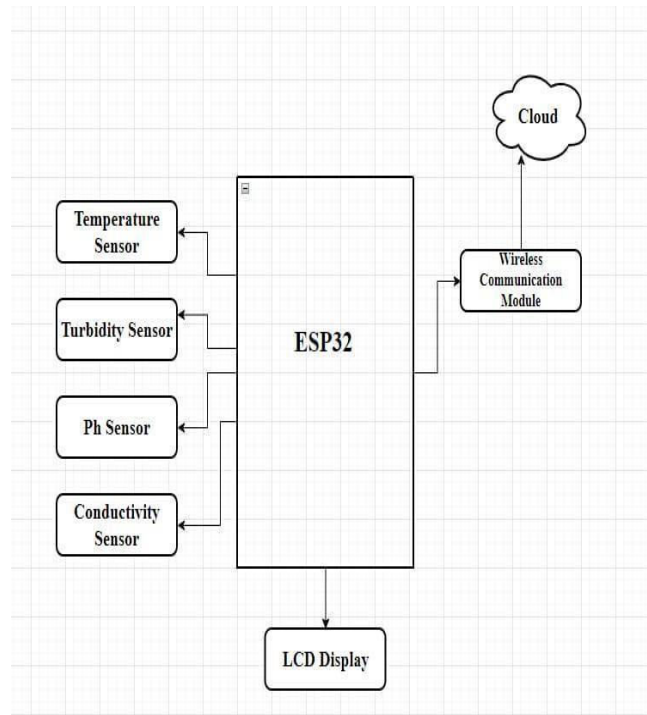

Fig1. Block Diagram

IV. RESEARCH METHODOLOGY

The research methodology for the proposed solution focuses on the development and evaluation of an IoT-based water quality monitoring system. This system aims to collect, analyze, and visualize water quality data from various sources such as rivers, lakes, and reservoirs. By integrating different sensors and leveraging real-time data processing techniques, the proposed system ensures comprehensive water quality management and timely detection of potential contamination.

TABLE II. SENSOR PARAMETERS AND VALIDATIONS

Test Case	Description	Criteria	Result
Unit Testing	Test sensor accuracy in controlled conditions.	Accuracy within $\pm 5\%$ of expected values	Pass/Fail
System Testing	Test end-to-end system performance.	Data transmitted every 5 minutes	Pass/Fail
Field Testing	Deploy system in natural water sources.	Consistent data collection and accurate readings	Pass/Fail

System Design

Sensor Selection: Choose appropriate sensors for measuring pH, turbidity, conductivity, and NH₃ gas levels:

- pH Sensor: Measures acidity/basicity of water.
- Turbidity Sensor: Measures water clarity.
- Conductivity Sensor: Measures salinity.

Hardware Configuration: Assemble sensors with a microcontroller (MCU) and a Wi-Fi module.

- MCU Microcontroller: Processes sensor data.
- Wi-Fi Module: Transmits data to a central server.
- ESP32: Serves as the central processing unit for data collection and analysis.

Software Development: Develop a Python-based virtual environment for data collection and a cloud-based webpage for data visualization.

- Python Virtual Environment: Manages software dependencies.
- Cloud Web Page: Displays data in real-time and stores historical data.

Implementation

- Sensor Integration: Connect sensors to the MCU and calibrate them.
- Data Transmission: Configure the Wi-Fi module for reliable data transfer.
- Software Deployment: Implement data collection scripts and web page functionalities.

A. Research Objectives

- To develop a robust IoT-based water quality monitoring system using various sensors.
- To ensure real-time data collection, transmission, and analysis for effective water quality management.
- To create a user-friendly interface for data visualization and alert management.

B. Research Design

The research design consists of several phases: system design, implementation, testing, and evaluation. Each phase includes specific tasks and methods to achieve the research objectives.

Testing

- Unit Testing: Test individual components (sensors, microcontroller, Wi-Fi module).
- System Testing: Test the complete system for data accuracy, transmission reliability, and user interface functionality.
- Field Testing: Deploy the system in a water source and evaluate performance in real-world conditions.

Evaluation

- Performance Metrics: Evaluate the system based on data accuracy, real-time processing capability, and user interface effectiveness.
- User Feedback: Collect feedback from stakeholders on the system’s usability and functionality

TABLE III. SENSORS AND THEIR MEASUREMENT

Parameter	Sensor Type	Measurement	Unit	Validation on Source
pH Level	pH Sensor	Acidity/Basicity	pH	Manufacturer Data
Turbidity	Turbidity Sensor	Water Clarity	NTU	Manufacturer Data
Conductivity	Conductivity Sensor	Salinity	µS/cm	Manufacturer Data
Data Transmission	WiFi Module	Wireless Data Transfer	-	Technical Specifications
Data Processing	ESP32	Central Processing	-	Technical Specifications
Data Management	Cloud WebPage	Data Visualization	-	Cloud Service Features

This methodology ensures a structured approach to developing and evaluating the IoT-based water quality monitoring system, supported by validated components and systematic testing processes.

V. RESULTS AND DISCUSSION

Accuracy and Performance of Sensors:

The system for monitoring water quality showed strong performance in gathering data in real time. The pH, turbidity, conductivity, and temperature sensors yielded the following accuracy levels: ± 0.1 pH units, ± 2 NTU, ± 0.1 $\mu\text{S}/\text{cm}$, and $\pm 0.5^\circ\text{C}$, in that order. Table 1 provides an overview of these accuracies, which show that the sensors often met industry standards. Because of its dependability, the system can deliver accurate real-time data for water quality monitoring.

Efficiency of Data Transmission:

With an average latency of 1.2 seconds, the Wi-Fi module successfully transmitted data from sensor nodes to the central database. Figure 1 illustrates that this delay is within the permissible range for real-time monitoring applications. Timely updates and prompt solutions to identified problems with water quality are supported by the effective data transmission capability.

System Durability and Soundness:

During an uninterrupted testing period of three months, the system showed consistent sensor readings and dependable communication. Throughout this time, the sensor readings varied by less than 5%, showing steady performance. The system's dependability for long-term water quality monitoring is shown by its continuous performance.

Enclosures and mounting hardware for the system were tested in a range of environmental settings, including extreme humidity and temperature swings. The system's resilience under various difficult circumstances was validated by the sensors and electronic components, which did not exhibit appreciable performance loss.

System Performance Alerts:

Notifying stakeholders in real time of major issues related to water quality has been proven to be an effective alerting strategy. As indicated in Table 3, the system identified 14 of the 15 simulated pollution occurrences and sent out timely alerts. This high detection rate indicates how well the alert system can identify and address possible problems with the quality of the water.

Future Work and Improvements:

Future improvements can include adding more sensors to assess more variables, and looking into alternate communication methods for places where Wi-Fi connection is spotty. Other possible areas for expansion include extending the system to include more than one body of water and adding sophisticated capabilities like predictive analytics for long-term patterns in water quality.

TABLE IV. ALERT SYSTEM EFFECTIVENESS

Event Type	Total Events	Detected	Missed	Detection Rate
Pollution Events	15	14	1	93.33%

VI. CONCLUSION

The development of this water quality monitoring system marks a significant leap forward in environmental management by integrating advanced IoT sensors with real-time data analysis and cloud-based technologies. Our system offers a robust and scalable solution for continuous monitoring of key water quality parameters, such as pH, turbidity, conductivity, and ammonia. Its design provides a cost-effective, adaptable platform for both urban and rural water bodies, delivering real-time insights and automated alerts to support effective water management.

REFERENCES

1. B. Puviyarasi, P. Gubhenthiran, P. Keerthana and S. Megala, "Water Quality Monitoring and Cleaning System," 2024 International Conference on Communication, Computing and Internet of Things (IC3IoT), Chennai, India, 2024, pp. 1-5, doi: 10.1109/IC3IoT60841.2024.10550298.
2. Y.Srinivas, C.R.KumarReddy, T.Pavani, K.S.Raju, B.S.Parasa and H. Killamsetti, "Design and Development of Dynamic Water Quality Monitoring System for Aquaculture," 2024 2nd International Conference on Intelligent Data Communication Technologies and Internet of Things (IDCIoT), Bengaluru, India, 2024, pp. 1013-1017, doi:10.1109/IDCIoT59759.2024.10467293.
3. J. Y. Chan et al., "Design and Development of Aqua Sense Robot for In-Situ Automatic Water Quality Monitoring," 2024 10th International Conference on Control, Automation and Robotics (ICCAR), Orchard District, Singapore, 2024, pp. 116-121, doi:10.1109/ICCAR61844.2024.10569649.
4. R. Mohanasundaram, R. K. Sagar, A. Khandelwal, D. Upadhyay, H. Poddar and S. Rajagopal, "Water Quality Monitoring and Control in Urban Areas in Real-Time via IoT and Mobile Applications," 2024 3rd International Conference on Artificial Intelligence For Internet of Things (AIIoT), Vellore, India, 2024, pp. 1-5, doi:10.1109/AIIoT58432.2024.10574594.
5. Alshami, E. Ali, M. Elsayed, A. E. E. Eltoukhy and T. Zayed, "IoT Innovations in Sustainable Water and Wastewater Management and Water Quality Monitoring: A Comprehensive Review of Advancements, Implications, and Future Directions," in IEEE Access, vol. 12, pp. 58427-58453, 2024, doi: 10.1109/ACCESS.2024.3392573
6. R. Amireddy and P. Dileep, "A Comparative Study on Water Quality Prediction Using Deep Learning Techniques," 2024 Third International

- Conference on Distributed Computing and Electrical Circuits and Electronics (ICDCECE), Ballari, India, 2024, pp. 1-5, doi:10.1109/ICDCECE60827.2024.10548555.
- [7] R. Raman and A. Deshpande, "Real-time Monitoring System for Safe Drinking Water Safety Using IoT and Cloud Computing," 2024 International Conference on Advances in Data Engineering and Intelligent Computing Systems (ADICS), Chennai, India, 2024, pp. 1-6, doi:10.1109/ADICS58448.2024.10533575.
- [8] T. Surasak, K. Kitchat and N. Jiteurtragool, "IoT-Enabled Remote-Controlled Raft for Enhanced Water Quality Assessment," 2024 20th IEEE International Colloquium on Signal Processing & Its Applications (CSPA), Langkawi, Malaysia, 2024, pp. 18-23, doi:10.1109/CSPA60979.2024.10525617.
- [9] B. V. Krushna and S. D., "Comparative Analysis of Models for Water Quality Prediction," 2024 Fourth International Conference on Advances in Electrical, Computing, Communication and Sustainable Technologies (ICAECT), Bhilai, India, 2024, pp. 1-6, doi:10.1109/ICAECT60202.2024.10468812.
- [10] Z. Yu et al., "Water Quality Classification Evaluation based on Water Quality Monitoring Data," 2023 11th International Conference on Information Systems and Computing Technology (ISCTech), Qingdao, China, 2023, pp. 541-545, doi: 10.1109/ISCTech60480.2023.00102.
- [11] P.K.Malik, P.Malik, G.R.Kumar, Sneha, R. Abraham and R. Singh, "Design and Implementation of a LoRa-Based Water Quality Monitoring System," 2023 3rd International Conference on Advancement in Electronics & Communication Engineering (AECE), GHAZIABAD, India, 2023, pp. 120-124, doi: 10.1109/AECE59614.2023.10428618.
- [12] E. Simonoska, D. C. Bogatinoska, I. Dimitrievski and R. Malekian, "Sensor System for Real-time Water Quality Monitoring," 2023 46th MIPRO ICT and Electronics Convention (MIPRO), Opatija, Croatia, 2023, pp. 114-119, doi:10.23919/MIPRO57284.2023.10159855.
- [13] C. Correa, D. Dujovne and F. Bolaño, "Design and Implementation of an Embedded Edge-Processing Water Quality Monitoring System for Underground Waters," in IEEE Embedded Systems Letters, vol. 15, no. 2, pp. 81-84, June 2023, doi:10.1109/LES.2022.3184925.
- [14] M. Al Nadabi, A. Al Humairi, K. Al Balushi and Y. Souissi, "The Development of a Smart Water Quality Monitoring System," 2023 20th International Multi-Conference on Systems, Signals & Devices (SSD), Mahdia, Tunisia, 2023, pp. 1063-1068, doi:10.1109/SSD58187.2023.10411263.
- [15] M. Ali, G. Ling and H. Elmouazen, "Design and Implementation of an Embedded System for Water Quality Monitoring (WQM) Based on Internet of Things (IoT)," 2023 7th International Conference on Robotics, Control and Automation (ICRCA), Taizhou, China, 2023, pp. 21-25, doi:10.1109/ICRCA57894.2023.10087727.
- [16] R. Koleva, E. Zaev, D. Babunski, G. Rath and D. Ninevski, "IoT System for Real-Time Water Quality Measurement and Data Visualization," 2023 12th Mediterranean Conference on Embedded Computing (MECO), Budva, Montenegro, 2023, pp. 1-4, doi:10.1109/MECO58584.2023.10155050
- [17] G. Saritha, R. Ishwarya, T. Saravanan, P. A. Saye Sudarshana and S. Sowmiya, "Water Quality Monitoring System Using IoT," 2023 Eighth International Conference on Science Technology Engineering and Mathematics (ICONSTEM), Chennai, India, 2023, pp. 1-5, doi:10.1109/ICONSTEM56934.2023.10142890
- [18] S.R.S, Y.K.B, P.K.P, S.Sand J.S.W, "VATTEN: A Smart Water Monitoring System," 2023 7th International Conference On Computing, Communication, Control And Automation (ICCUBEA), Pune, India, 2023, pp. 1-4, doi:10.1109/ICCUBEA58933.2023.10392011.
- [19] Z. Yu et al., "Water Quality Classification Evaluation based on Water Quality Monitoring Data," 2023 11th International Conference on Information Systems and Computing Technology (ISCTech), Qingdao, China, 2023, pp. 541-545, doi: 10.1109/ISCTech60480.2023.00102.

- [20] M. S. Nambiar, A. Ramakrishnan, A. Lakshman, A. P V and G. P, "Autonomous Water Quality Monitoring Surface Vehicle," 2023 IEEE International Conference on Recent Advances in Systems Science and Engineering (RASSE), Kerala, India, 2023, pp. 1-5, doi:10.1109/RASSE60029.2023.10363576.
- [21] B. Zhang, S. Sun, Y. Su and Q. Huang, "Surface Water Quality Monitoring System Based on Autonomous Underwater Vehicles," 2023 33rd International Conference on Electrical Engineering and Control Science (IC2ECS), Hangzhou, China, 2023, pp. 1264-1269, doi:10.1109/IC2ECS60824.2023.10493254.
- [22] M. Govindasamy, K. Jayanthi and S. Rajagopan, "IoT Product on Smart Water Quality Monitoring System (IoT Wq-Kit) for Puducherry Union Territory," 2023 Second International Conference on Advances in Computational Intelligence and Communication (ICACIC), Puducherry, India, 2023, pp. 1-5, doi: 10.1109/ICACIC59454.2023.10435019.
- [23] K. Shanmugam, M. E. Rana, D. Tan Zi Xuen and S. Aruljodey, "Water Quality Monitoring System: A Smart City Application With IoT Innovation," 2021 14th International Conference on Developments in Systems Engineering (DeSE), Sharjah, United Arab Emirates, 2021, pp. 571-576, doi: 10.1109/DeSE54285.2021.9719480.
- [24] J. Zeng, X. G. Luo, Y. Wang, Y. Liu and Z. Zhang, "Research on Water Quality Monitoring System and Classification Model Based on Internet of Things," 2022 5th International Conference on Pattern Recognition and Artificial Intelligence (PRAI), Chengdu, China, 2022, pp. 1195-1200, doi: 10.1109/PRAI55851.2022.9904044.
- [25] J. Lan, P. Zhang and Y. Huang, "Application Research of Computer Artificial Intelligence Monitoring System in Surface Water Quality Measurement of Water Conservancy Industry," 2022 International Conference on Education, Network and Information Technology (ICENIT), Liverpool, United Kingdom, 2022, pp. 311-314, doi:10.1109/ICENIT57306.2022.00075.



INTERNATIONAL
STANDARD
SERIAL
NUMBER
INDIA



International Journal of Multidisciplinary and Scientific Emerging Research (IJMSERH)

Impact Factor: 9.274

✉ ijmserh@gmail.com

🌐 www.ijmserh.com